

## 60 & 96 W, Efficient, Compact CV Class 2 LED Drivers in a Junction Box

Nominal Input Voltage	Max. Output Power	Nominal Output Voltage	Max. Output Current	Efficiency	Max. Case Temperature	THD	Power Factor
120 & 277 Vac	96 W	12, 24, 48 Vdc	5, 4, 2 A	up to 92% typical	90°C (measured at the hot spot)	< 20%	> 0.9

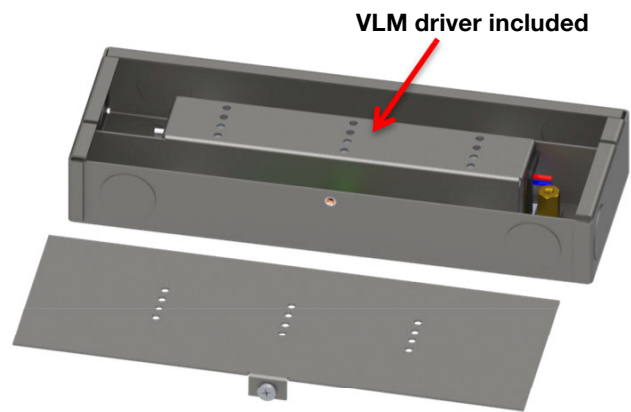

**Dimensions**  
L 207.2 x W 75.4 x H 33 mm  
(L 8.16 x W 2.97 x H 1.30 in)



Typical Application Diagram



Wiring Diagram

### FEATURES

- Low profile, rugged steel enclosure designed for use with our Constant Voltage VLM series.
- JVLM is Plenum-rated, so it can go in air handling spaces. (In building construction, the plenum is the space that is used for air circulation in heating and air conditioning systems, typically between the structural ceiling and the suspended ceiling or under a raised floor).
- Designed for contractor installation:
  - UL listed
  - Separation of low-voltage wiring and high-voltage wiring
  - 4 mounting holes for surface mounting
  - 4 knockout holes for low-voltage wiring and 4 knockout holes for high-voltage wiring enable maximum wiring flexibility
- Same electrical features as the VLM series
- IP20-rated case
- Patent protected

### TYPICAL APPLICATIONS

- Strip lights
- Pendants
- Linears
- Cove Lights



## 60 & 96 W, Efficient, Compact CV Class 2 LED Drivers in a Junction Box

### 1 - ORDERING INFORMATION

Part Number	Nominal Input Voltage (Vac)	Pout Max (W)	Vout Nom (Vdc)	Iout Min (A)	Iout Max (A)	Open Loop Voltage (No Load Vout Max) (Vdc)	Comments
<b>JVLM100</b>							
JVLM100W-24	120 & 277	96	24	0.2	4	25.68	Contains the VLM100W-24 in the aluminum case with flying leads
JVLM100W-48	120 & 277	96	48	0.1	2	51.36	Contains the VLM100W-48 in the aluminum case with flying leads
<b>JVLM60</b>							
JVLM60W-12	120 & 277	60	12	0.1	5	12.84	Contains the VLM60W-12 in the aluminum case with flying leads
JVLM60W-24	120 & 277	60	24	0.1	2.5	25.68	Contains the VLM60W-24 in the aluminum case with flying leads
JVLM60W-48	120 & 277	60	48	0	1.3	51.36	Contains the VLM60W-48 in the aluminum case with flying leads

## 60 & 96 W, Efficient, Compact CV Class 2 LED Drivers in a Junction Box

### 2 - INPUT SPECIFICATION (@25° C ambient temperature)

	Units	Minimum	Typical	Maximum	Notes
<b>Input Voltage Range (Vin)</b>	Vac	90	120 & 277	305	<ul style="list-style-type: none"> <li>The rated output voltage for each model is achieved at Vin≥105 Vac &amp; at Vin≥249 Vac</li> <li>At maximum load, as specified in section 1.</li> </ul>
<b>Input Frequency Range</b>	Hz	47	60	63	
<b>Input Current (Iin)</b>	A			1.05 A @ 120 Vac 0.48 A @ 277 Vac	
<b>Power Factor (PF)</b>		0.9	> 0.9		<ul style="list-style-type: none"> <li>At nominal input voltage</li> <li>From 100% to 60% of rated power</li> </ul>
<b>Inrush Current</b>	A	Meets NEMA-410 requirements			At any point on the sine wave and 25°C
<b>Leakage Current</b>	µA			400 µA @ 120 Vac 920 µA @ 277 Vac	Measured per IEC60950-1
<b>Input Harmonics</b>	Complies with IEC61000-3-2 for Class C equipment				
<b>Total Harmonics Distortion (THD)</b>				20%	<ul style="list-style-type: none"> <li>At nominal input voltage</li> <li>From 100% to 60% of rated power</li> <li>Complies with DLC (Design Light Consortium) technical requirements</li> </ul>
<b>Efficiency</b>	%	-	up to 92%	-	Measured with nominal input voltage
<b>Isolation</b>	The AC input to the main DC output is isolated.				

### 3 - MAIN OUTPUT SPECIFICATION (@25° C ambient temperature)

	Units	Minimum	Typical	Maximum	Notes
<b>Output Voltage (Vout)</b>	Vdc		12, 24, 48		See ordering information for details
<b>Output Current (Iout)</b>	A			12 Vdc: 5 A 24 Vdc: 4 A 48 Vdc: 2 A	The rated output voltage for each model is achieved at Vin≥105 Vac & at Vin≥249 Vac
<b>Output Voltage Regulation</b>	%	-5		5	<ul style="list-style-type: none"> <li>At nominal AC line voltage</li> <li>Includes load and current set point variations.</li> </ul>
<b>Output Voltage Overshoot</b>	%	-	-	10	The driver does not operate outside of the regulation requirements for more than 500 ms during power on with maximum load.
<b>Ripple Voltage</b>	≤ 5% of rated output voltage for each model				<ul style="list-style-type: none"> <li>Measured at maximum load and nominal input voltage.</li> <li>Calculated in accordance with the IES Lighting Handbook, 9th edition.</li> </ul>
<b>Start-up Time</b>	ms			500	<ul style="list-style-type: none"> <li>Measured from application of AC line voltage to 100% light output.</li> <li>Complies with ENERGY STAR® luminaire specification.</li> </ul>

## 60 & 96 W, Efficient, Compact CV Class 2 LED Drivers in a Junction Box

### 4 - ENVIRONMENTAL CONDITIONS (Please refer to the VLM100 and VLM60 data sheets)

	Units	Minimum	Typical	Maximum	Notes
Operating Ambient Temperature (Ta)	°C	-20		40	
Maximum Case Temperature (Tc)	°C			+90	Please refer to the VLM100 and VLM60 data sheets.
Storage Temperature	°C	-40		+85	
Humidity	%	5	-	95	Non-condensing
Cooling	Convection cooled				
Acoustic Noise	dBA			22	Measured at a distance of 1 foot (30 cm)
Mechanical Shock Protection	per EN60068-2-27				
Vibration Protection	per EN60068-2-6 & EN60068-2-64				
MTBF	Please refer to the VLM100 and VLM60 data sheets.				
Lifetime	Please refer to the VLM100 and VLM60 data sheets.				

### 5 - EMC COMPLIANCE AND SAFETY APPROVALS (Please refer to the VLM100 and VLM60 data sheets)

EMC Compliance		
Conducted and Radiated EMI	FCC CFR Title 47 Part 15 Class B at 120 Vac and Class A at 277 Vac	
Harmonic Current Emissions	IEC61000-3-2	For Class C equipment
Voltage Fluctuations & Flicker	IEC61000-3-3	
Immunity Compliance	ESD (Electrostatic Discharge)	IEC61000-4-2 6 kV contact discharge, 8 kV air discharge, level 3
	RF Electromagnetic Field Susceptibility	IEC61000-4-3 3 V/m, 80 - 1000 MHz, 80% modulated at a distance of 3 meters
	Electrical Fast Transient	IEC61000-4-4 ± 2 kV on AC power port for 1 minute, ±1 kV on signal/control lines
	Surge	IEC61000-4-5 ± 2 kV line to line (differential mode) / ± 2 kV line to common mode ground (tested to secondary ground) on AC power port, ±0.5 kV for outdoor cables ANSI/IEEE c62.41.1-2002 & c62.41.2-2002 category A, 2.5 kV ring wave
	Conducted RF Disturbances	IEC61000-4-6 3V, 0.15-80 MHz, 80% modulated
	Voltage Dips	IEC61000-4-11 >95% dip, 0.5 period; 30% dip, 25 periods; 95% reduction, 250 periods

#### Safety Agency Approvals

UL	UL2108
cUL	CAN/CSA C22.2 No. 250.0-08

#### Safety

	Units	Minimum	Typical	Maximum	Notes
Hi Pot (High Potential) or Dielectric voltage-withstand	Vdc	2500			<ul style="list-style-type: none"> <li>Insulation between the input (AC line and Neutral) and the output</li> <li>Tested at the RMS voltage equivalent of 1768 Vac</li> </ul>

### 6 - OTHER CHARACTERISTICS

For information on other characteristics such as protections, lifetime, efficiency, THD, PF curves, please refer to the VLM100 and VLM60 data sheets.

## 60 & 96 W, Efficient, Compact CV Class 2 LED Drivers in a Junction Box

### 7 - PREDICTED LIFETIME VERSUS CASE AND AMBIENT TEMPERATURE

Lifetime is defined by the measurement of the temperatures of all the electrolytic capacitors whose failure would affect light output under the nominal LED load and worst case AC line voltage. The graphs in figures 2 and 3 are determined by the electrolytic capacitor with the shortest lifetime, among all electrolytic capacitors. It represents a worst case scenario in which the LED driver is powered 24 hours/day, 7 days/week. The lifetime of an electrolytic capacitor is measured when any of the following changes in performance are observed:

- 1) Capacitance changes more than 20% of initial value
- 2) Dissipation Factor ( $\tan \delta$ ): 150% or less of initial specified value
- 3) Equivalent Series Resistance (ESR): 150% or less of initial specified value
- 4) Leakage current: less of initial specified value

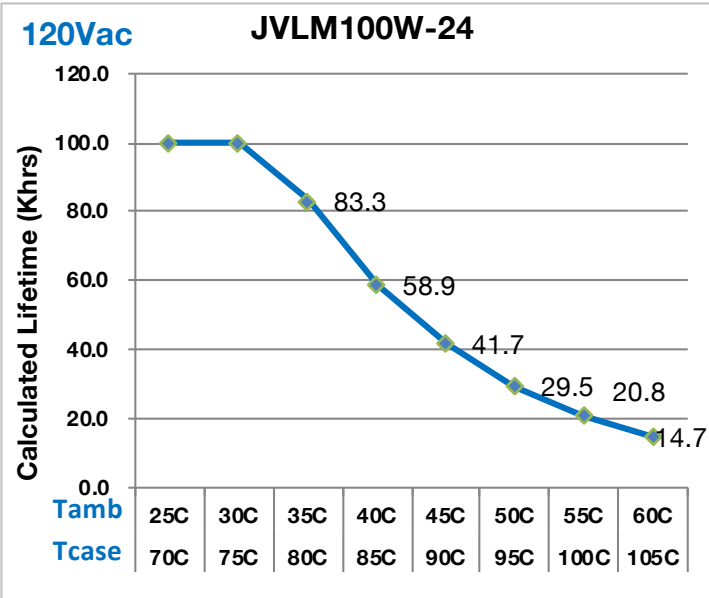

Figure 1

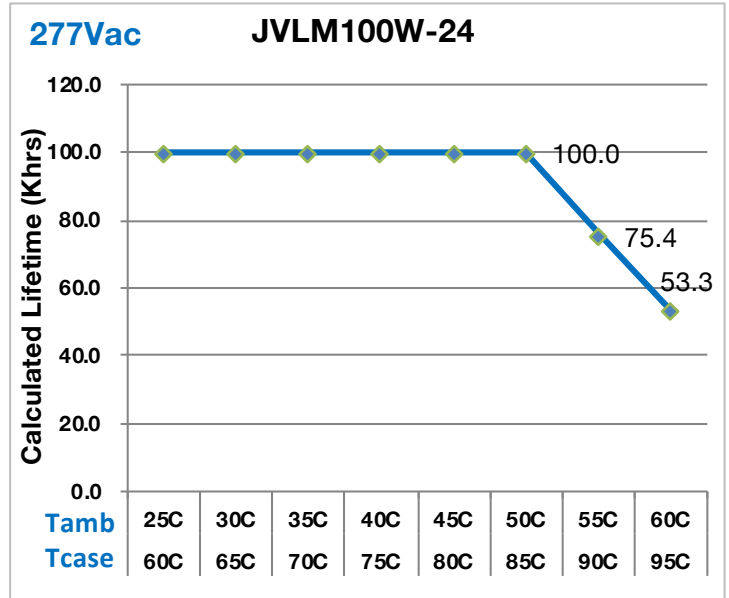

Figure 2

Notes:

- The ambient temperature  $T_{ambient}$  and the differential between  $T_{ambient}$  and  $T_{case}$  mentioned in the above graphs are relevant only as long as both the driver and the light fixture are exposed to the same ambient room temperature. If the LED driver is housed in an enclosure or covered by insulation material, then the ambient room temperature is no longer valid. In this situation, please refer only to the case temperature  $T_{case}$ .
- It should be noted the graph "Lifetime vs. Ambient Temperature" may have an error induced in the final application if the mounting has restricted convection flow around the case. For applications where this is evident, the actual case temperature measured at the  $T_c$  point in the application should be used for reliability calculations.

## 60 & 96 W, Efficient, Compact CV Class 2 LED Drivers in a Junction Box

### 8 - MECHANICAL DETAILS

- **Packaging Type:** Galvanized steel
- **I/O Connections:** See installation guide
- **Ingress Protection:** IP20 rated

### 9 - OUTLINE DRAWINGS

- **Dimensions:** L 207.2 x W 75.4 x H 33 mm (L 8.16 x W 2.97 x H 1.30 in)
- **Volume:**

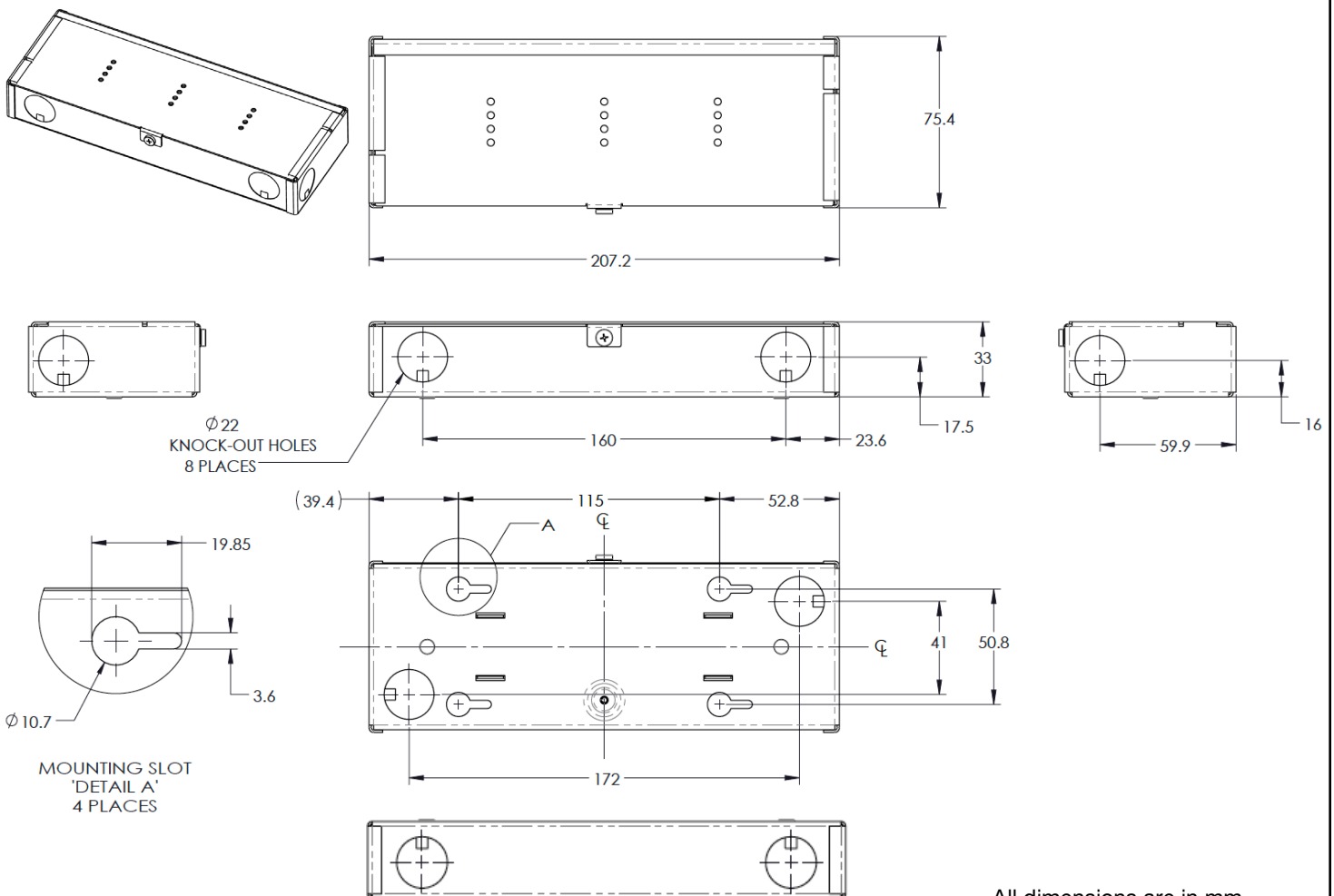

All dimensions are in mm

**Figure 3**





# JVLM Series

JVLM60W 60 W  
JVLM100W 96 W

## 60 & 96 W, Efficient, Compact CV Class 2 LED Drivers in a Junction Box

### 10 - LABELING

The JVLM100W-24 is used as an example to illustrate a typical label.

 <b>JVLM100W-24</b> Junction Box with integrated Constant Voltage LED Driver	<b>AC INPUT:</b> 120/277 V ~ 1.05 A 50/60 Hz PF ≥ 0.9 THD ≤ 20%	<b>DC OUTPUT:</b> Max Current 4 A --- Maximum Power 96 W Regulated Voltage 24 Vdc 
---	---	--

**USA Headquarters**  
 Tel: +1-805-517-1300  
 Fax: +1-805-517-1411  
 893 Patriot Drive, Suite E,  
 Moorpark, CA 93021, USA

**CHINA Operations**  
 Tel: +86-756-6266298  
 Fax: +86-756-6266299  
 No. 8 Pingdong Road 2  
 Zhuhai, Guangdong, China 519060

ERP Power, LLC (ERP) reserves the right to make changes without further notice to any products herein. ERP makes no warranty, representation or guarantee regarding the suitability of its products for any particular purpose, nor does ERP assume any liability arising out of the application or use of any product or circuit, and specifically disclaims any and all liability, including without limitation special, consequential or incidental damages. "Typical" parameters which may be provided in ERP data sheets and/or specifications can and do vary in different applications and actual performance may vary over time. All operating parameters, including "Typicals" must be validated for each customer application by customer's technical experts. ERP does not convey any license under its patent rights nor the rights of others. ERP products are not designed, intended, or authorized for use as components in systems intended for surgical implant into the body, or other applications intended to support or sustain life, or for any other application in which the failure of the ERP product could create a situation where personal injury or death may occur. Should Buyer purchase or use ERP products for any such unintended or unauthorized application, Buyer shall indemnify and hold ERP and its officers, employees, subsidiaries, affiliates, and distributors harmless against all claims, costs, damages, and expenses, and reasonable attorney fees arising out of, directly or indirectly, any claim of personal injury or death associated with such unintended or unauthorized use, even if such claim alleges that ERP was negligent regarding the design or manufacture of the part. ERP is an Equal Opportunity/Affirmative Action Employer. This literature is subject to all applicable copyright laws and is not for resale in any manner.