

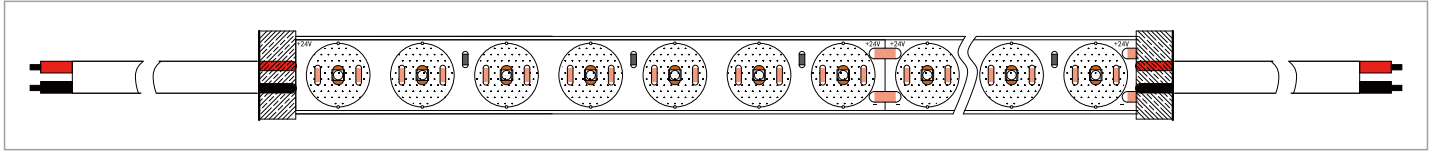

FlexWash Installation



Self-Processed Version (the cap with bigger size than the main body)

 <p>Front Cap End Cap</p>	<p>Following the mark line for cutting by scissors.</p> 	<p>Peel off the silicone jacket on the top side by 3mm [0.12in.] length and exposure the solder pad.</p> 
<p>Solder the cable to the solder pads on top side of the strip.</p> 	<p>Fill the front cap with silicone glue and seal to the LED strip.</p> 	<p>Fill the end cap with silicone glue and seal to the LED strip.</p> 

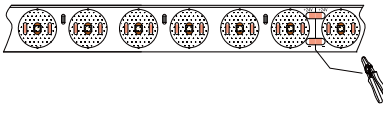
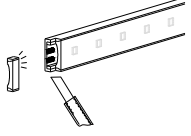
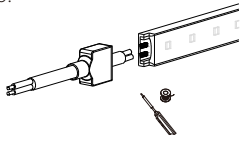
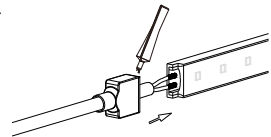
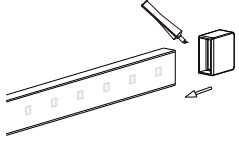
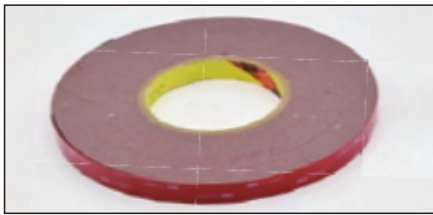

(1) Adhesive Tape

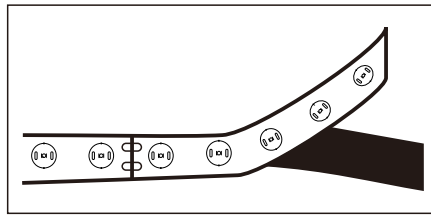

① Peel off the release paper of 3M tape.

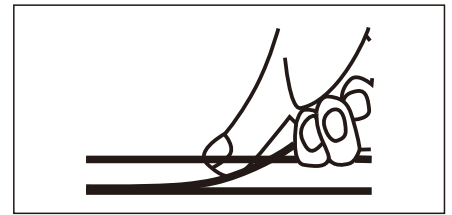

② Stick and fix the LED strip to the mounting surface.



(2) Bracket & Aluminum Channel & Screw
Or
(3) Bracket & Aluminum Channel & Screw & Cover & Cap

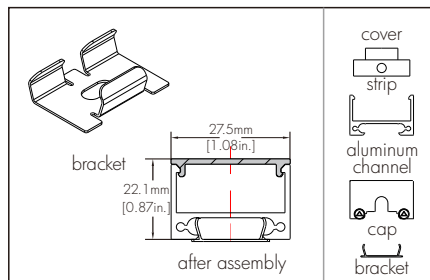

Fix the bracket to the mounting surface by screw. ② Fix the strip to the aluminum channel by adhesive tape.
③ Fix the cover and the cap to the aluminum channel by screw. ④ Clip the aluminum channel to the bracket.

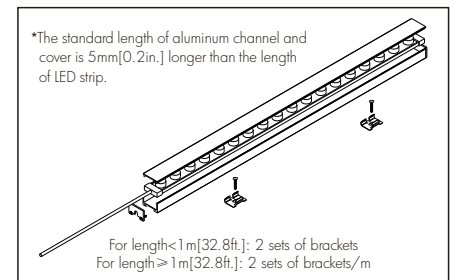

(4) 120° Rotatable Bracket & Aluminum Channel & Cover & Cap & Screw

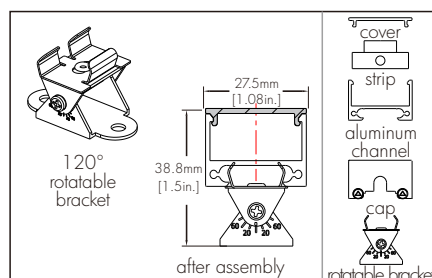

Fix the bracket to the mounting surface by screw. ② Fix the strip to the aluminum channel by adhesive tape.
③ Fix the cover and the cap to the aluminum channel by screw. ④ Clip the aluminum channel to the rotatable bracket.

